



Bratislava 10.01.2024

UP TO YOU sro - Bratislava
WE OFFER SOLUTIONS

Za Stanicou 10
831 04 Bratislava (SK)
SK2120586292

Operative Contacts
Marco Boemio
C.E.O

Mob +421 948 223435
Mail info@uptoyou.sk



CASE STUDY List 13-101-2023

Clean TeQ Water Limited

Bratislava 10.01.2024

**INSTALLATION IN DUBAI
LABOR VILLAGE 2 - 2017**

DATA COLLECTION

In December 2017, We installed an AWA 250 HWAC machine (called AWA 250 in the current document for shortness) in a worker village (named Labour Village 2 in the following 2 pictures) placed not very far from Dubai.
The scope was to carry out a working test of the machine in order to determine its Pay Back Time for the worker village owners.





CASE STUDY List 13-101-2023

Clean TeQ Water Limited

Bratislava 10.01.2024

INSTALLATION IN DUBAI LABOR VILLAGE 2 – 2017

DATA COLLECTION

DUBAI CLIMATE

Taking into account statistical weather data, coming from a weather station placed in the Dubai airport, it was possible to determine the following table.

Data base *	Jan	Feb	Mar	Apr	May	Jun	Jul	Aug	Sep	Oct	Nov	Dec
Avg Day Temp °C	20,6	21,7	24,4	28,5	32,8	34,2	37	36,8	34,4	31,2	26,5	22,3
Avg Day Humidity %	59,7	56,5	53,2	46,6	39,5	48,8	44,5	44,6	51,5	54,4	53,7	57,4

Considering the previous table, Dubai has an almost dry hot climate.

The AWA machine average water production, in such weather conditions, is about 1.650lt/day.

WORKER VILLAGE EXISTING PLANT DESCRIPTION

The worker village has several buildings.

The actual heating plant, for each building, is composed by 24 electrical boilers of 1.5kW, which works 12h/day.

Such an energy amount can heat about 12.000lt/day of domestic water (temperature difference provided: 30*)



CASE STUDY List 13-101-2023

Clean TeQ Water Limited

Bratislava 10.01.2024

INSTALLATION IN DUBAI

LABOR VILLAGE 2 - 2017

DATA COLLECTION

WORKER VILLAGE EXISTING PLANT DESCRIPTION

Moreover in one of the buildings, where are based all the kitchens and services for workers, is based a LPG boiler, with an estimated efficiency of 70% and averagely heats about 20.000lt/day of domestic water (temperature difference provided 30*).

Furthermore, such a building has an air conditioning system, which has also a duct system equipped with fans (fan motors energy consumption: 144kWh/day)

WATER & ENERGY COST

On the basis of data collected from worker village managers, it was possible determine the following table of costs

description	Measure unit	cost
Electrical energy	AED/kWh	0.44
LPG	AED/litre	1.9
High quality drinking water	AED/litre	0.5

N.B.

AED is the Dubai Currency. The exchange value on USDollar is 0.2724 (11/04/2017)



CASE STUDY List 13-101-2023

Clean TeQ Water Limited

Bratislava 10.01.2024

**INSTALLATION IN DUBAI
LABOR VILLAGE 2 - 2017**

DATA COLLECTION

AWA 250 INSTALLATION SCHEME AND SHORT TEST DESCRIPTION

The AWA 250 machine was installed on concrete basement, in external, nearby the village kitchens, where the test has been performed.

Fresh and dry air, produced by the AWA machine, were directly delivered into the kitchen area. A pipeline linked the existing domestic water tank to the AWA 250 condensation plate coils. Moreover, the drinking water was collected in tank.

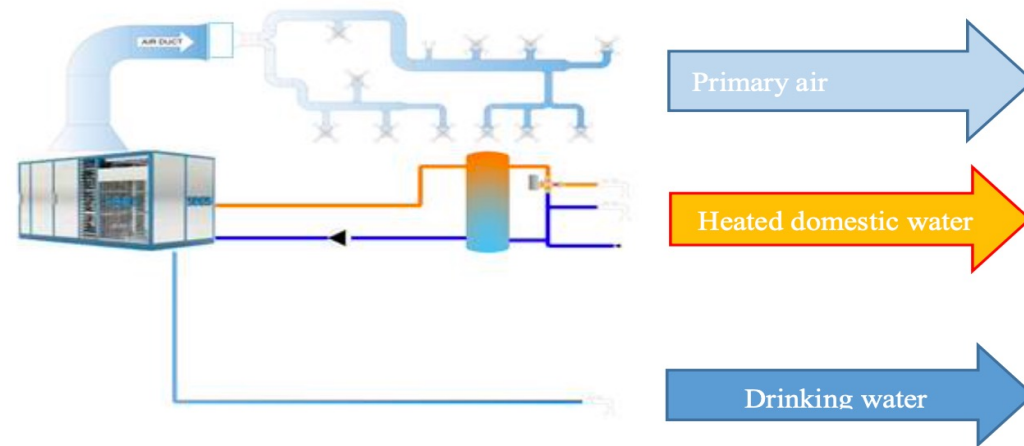

Fig. 3. AWA installation scheme



CASE STUDY List 13-101-2023
Clean TeQ Water Limited
Bratislava 10.01.2024

INSTALLATION IN DUBAI
LABOR VILLAGE 2 – 2017

DATA COLLECTION

AWA 250 INSTALLATION SCHEME AND SHORT TEST DESCRIPTION



AWA 250 on site



CASE STUDY List 13-101-2023

Clean TeQ Water Limited

Bratislava 10.01.2024

INSTALLATION IN DUBAI LABOR VILLAGE 2

DATA COLLECTION

AWA 250 INSTALLATION SCHEME AND SHORT TEST DESCRIPTION

The test has been carried out for about 3 months and, during that time, several data were collected, such as:

- ✓ Temperature and relative humidity
- ✓ Produced water
- ✓ Energy consumption
- ✓ Heated domestic water flux and achieved temperature

Worker village technicians monitored the test on site, while We made controls, by remote, using the AWA control satellite device technology.



CASE STUDY List 13-101-2023

Clean TeQ Water Limited

Bratislava 10.01.2024

INSTALLATION IN DUBAI LABOR VILLAGE 2

RESULTS

On the basis of data coming from the test it was possible to define the following results:

- AWA 250 heating capacity: enough to serve five buidings of the worker village and save: 2.160kWh of electrical power due to boilers, equal to 950AED/day
Moreover, there is enough thermal energy left to serve the kitchen boiler and save: 154lt/day of LPG, equal to 293AED/day
- Awa 250 average water production: 1.646lt/day of high quality drinking water, equal to 829AED/day
- AWA 250 cooling power is enough to replace existing air conditioning and fan motors to achieve daily electrical energy saving of: 480kWh equal to 211 AED/day

While the AWA 250 average electrical energy consumption is 800kWh/day, equal to a cost of 352AED/day

AWA 250 daily cost for maintenace and consumables is: 139.9AED/day



CASE STUDY List 13-101-2023
Clean TeQ Water Limited
Bratislava 10.01.2024

INSTALLATION IN DUBAI
LABOR VILLAGE 2 - 2017

RESULTS

The following table shows the previous results:

description	Measure unit	results	AED/day	
Electrical energy saving	kWh/day	2640	1161.6	
LPG saving	litre/day	154	293	
Water saving	litre/day	1646	823	
AWA costs				
Electrical consumption	kWh/day	800	352	
Consumables and maintenance			139.3	
Final result				
Net daily saving			1,785.88	
Net yearly saving			651,846	



CASE STUDY List 13-101-2023

Clean TeQ Water Limited

Bratislava 10.01.2024

**INSTALLATION IN DUBAI
LABOR VILLAGE 2**

CONCLUSIONS

PAY BACK TIME EVALUATION

On the basis of the previous results, it was possible calculate the PBT of the AWA 250, considering the following prices:

<u>Description</u>	<u>Costs AED currency</u>
AWA 250 HWAC model	1,180,480.00
Installation	57,500.00
Total Cost	1,237,980.00

Thus the PBT is less than 2 years (1 year and 11 months)